



RIGGING ADVISORY CIRCULAR

Issue Date: 01 November 1985

RAC No. 403 Rev. A

SUBJECT SST SERVICE BULLETIN

STATUS Recommended

BACKGROUND The pull force required to pull the pins on the reserve ripcord cannot exceed 22 lbs (safety tie removed).

With an SST or any other reserve using locking loops the required pull force is a result of the amount of tension the loops put on the pins. This, in turn is affected by the volume of the packed canopy.

Canopy volume varies from type and even from one canopy to another of the same type.

Riggers assembling a reserve parachute should insure that the force required to pull the pins is within specifications. If a greater pull force is experience, than a longer loop should be installed.

MANUFACTURER ADVISORY

The current method of attaching the reserve ripcord housing to the container (Fig.1) can possibly contribute to a hard (but not impossible) pull when the container is in an extremely abnormal position.

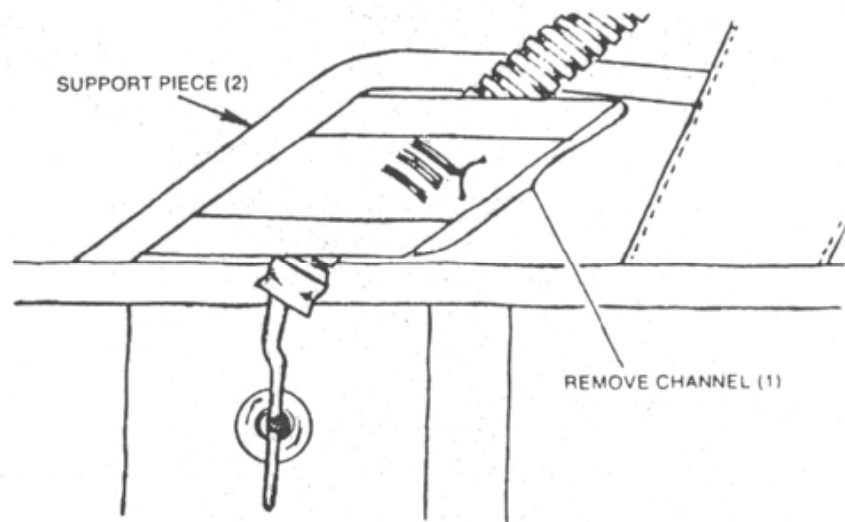

FIGURE 1



RIGGING ADVISORY CIRCULAR

Issue Date: 01 November 1985

RAC No. 403 Rev. A

To insure consistent pull force regardless of the position of the rig, the modified attachment method (Fig. 2) should be installed on all SST's. To accomplish this:

1. Remove the tacking at the container end of the housing and remove the housing from the channel. (1) on the support piece (2) and remove the channel by cutting the stitches.
2. Position the housing as illustrated on Fig.2 when the housing is straight across the top of the container the end should line up with the centre line of the container.
3. Using 3 turns of 5 cord nylon, waxed and doubled, tack at Point A, and Point B and C. Secure with a surgeon's and locking knot and cut, leaving a 1" tail.
4. Notify the Jump Shack of the Serial Number of the Units modified.

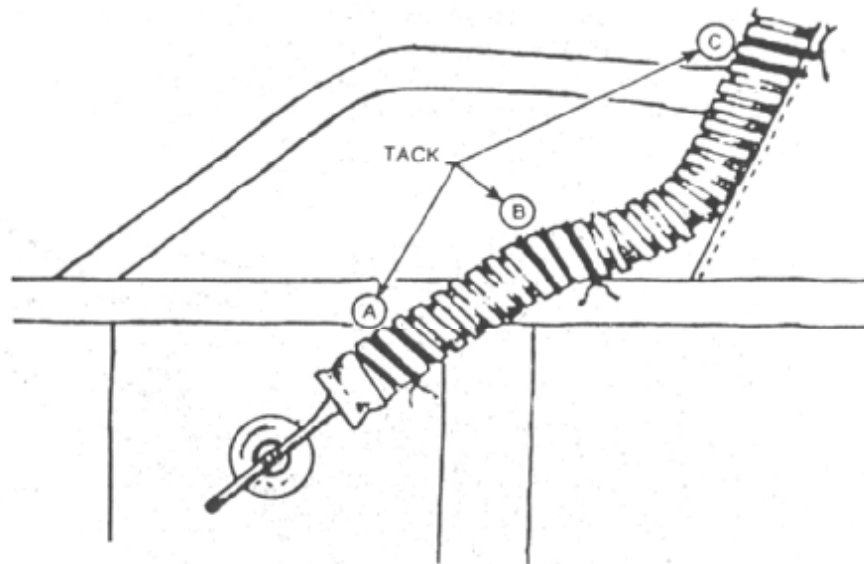

FIGURE 2

EFFECTIVE DATE: May 1976

AUTHORITY: The Jump Shack through USPA Parachutist Magazine

DISTRIBUTION: APF Packers and Riggers
NZPF Parachute Technicians