



PARACHUTES AUSTRALIA

22 Bosci Rd, Ingleburn NSW 2565 Australia (P:O Box 969)
Ph: + 61 2 98295355 Fax: +61 2 98291300

SERVICE BULLETIN No PA SB9702

Issued 1 July 1998

SUBJECT: PIGMEE RAM-AIR RESERVE FREEBAG UPGRADE

STATUS: RECOMMENDED

IDENTIFICATION: Parachutes Australia Pigmee, all models, fitted with a ram-air reserve in a freebag and used for student training.

BACKGROUND: Over the years the Pigmee system ram-air reserve freebag has been upgraded. Earlier ones were constructed from a lightweight material. Later ones use a heavier material. Later production bags also have an inverted "V" added to spread the load where the bridle attaches to the top of the bag. Currently manufactured bags have provision for the through-the-bag loops to compress the reserve and give greater protection from accidental activation on aircraft exit.

The 1997 APF Technical Conference discussed the relative merits of the latest freebag compared with earlier versions and recommended that student training operations using the Pigmee be encouraged to use the current production bag.

MANUFACTURER ADVISORY:

Older bags in good condition, other than those constructed from F111 may be upgraded by a Rigger B. F111 freebags are not suitable for modification. Remove the 2 closing loops from the reserve container side flaps. It is not necessary to remove the loop anchor tabs.

Do not remove the freebag bridle hesitator loop system.

New freebags, instructions for modifying older bags, and reserve packing instructions for a through-the-bag freebag are available from the manufacturer.

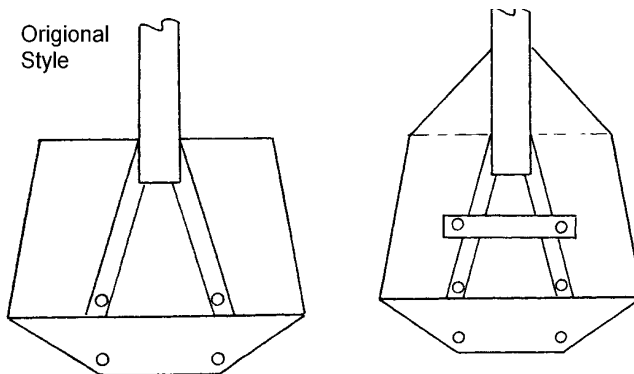

Current style using 210 denier Oxford Nylon Cloth

AUTHORITY: Managing Director Underline Designs Pty Ltd trading as Parachutes Australia.

COMPLIANCE DATE: Next periodic inspection

DISTRIBUTION: Subscribers to the APF Service Bulletin service.