

**Concerned equipment: BT80 Main canopy (civilian & military versions)**

**Reported incident:** Locking of slider during opening stage by routing of line attachment tape through front slider's grommet (front external line : #1 & #10 , group "A").

**Analysis:** a differential ageing of external "B" lines where slider stops are located might induce differential lengthening with "A" lines.

Attachment tapes of external A line shall then route through slider grommet before stopping of grommets by B lines stop grommets.

## Checking

Anchor the front line group rapid links and tighten the external A and B lines to check and compare the final length level

### RIGHT

The potential locking area is placed above the max. slider grommet level.

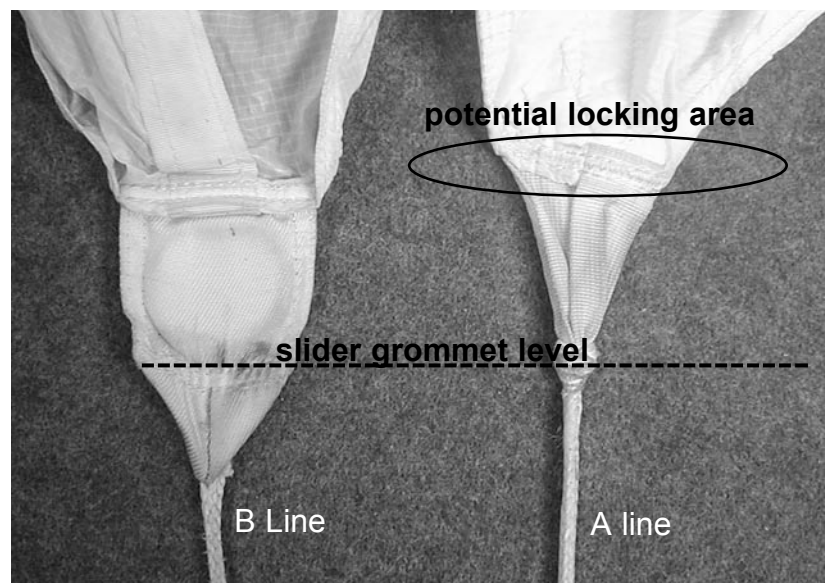

### WRONG

The potential locking area is placed under the max. slider grommet level.

### MANDATORY UPGRADING

**SEWING OF SLIDER STOPS ON EXTERNAL "A" LINES**  
(refer to pages: 2-5)

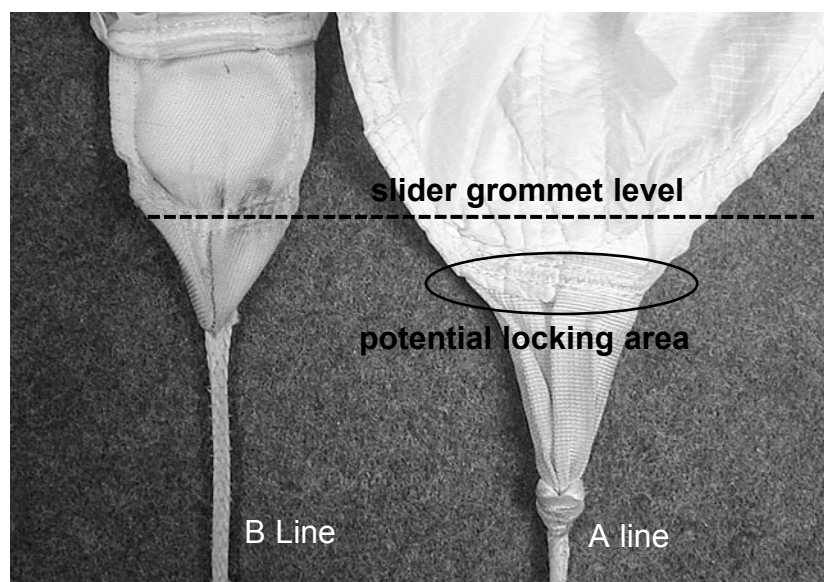

This modus operandi is regarding the installation of slider stops on external attachment tapes ( group A right & left).

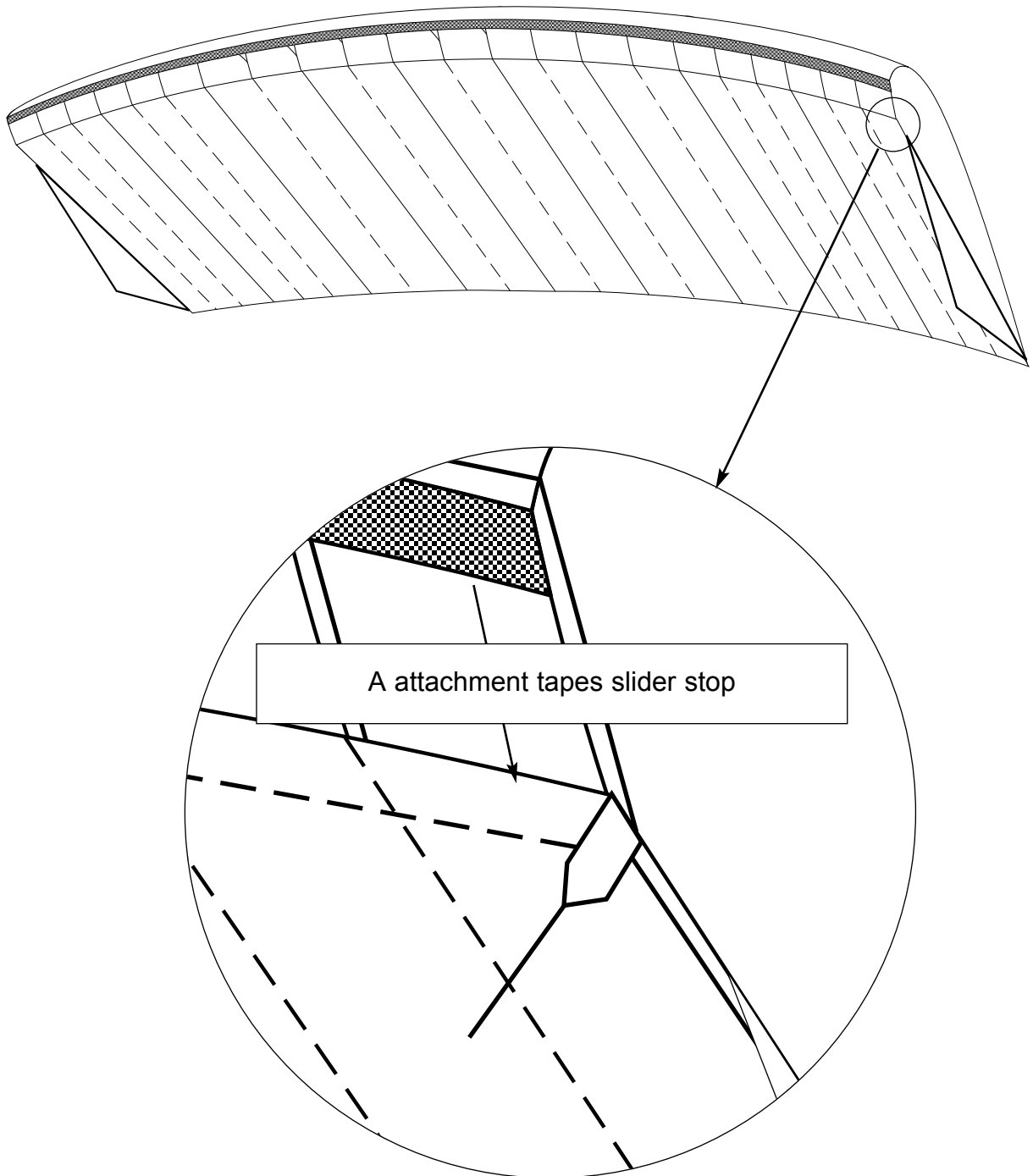

**BT80 M A attachment tapes slider stops installation**

PdF supplies	:	Polyester 55 mm webbing mini	2 x 21 cm	P/N:9002100000
Stop ring	:	2 per canopy		P/N:9001260200
qualification level	:	Rigger		
Tools	:	Sewing machine 2 needles 4,8 mm	Thread: 4 kg	

Edge of 21 cm polyester 55 mm webbing must be cut with hotknife

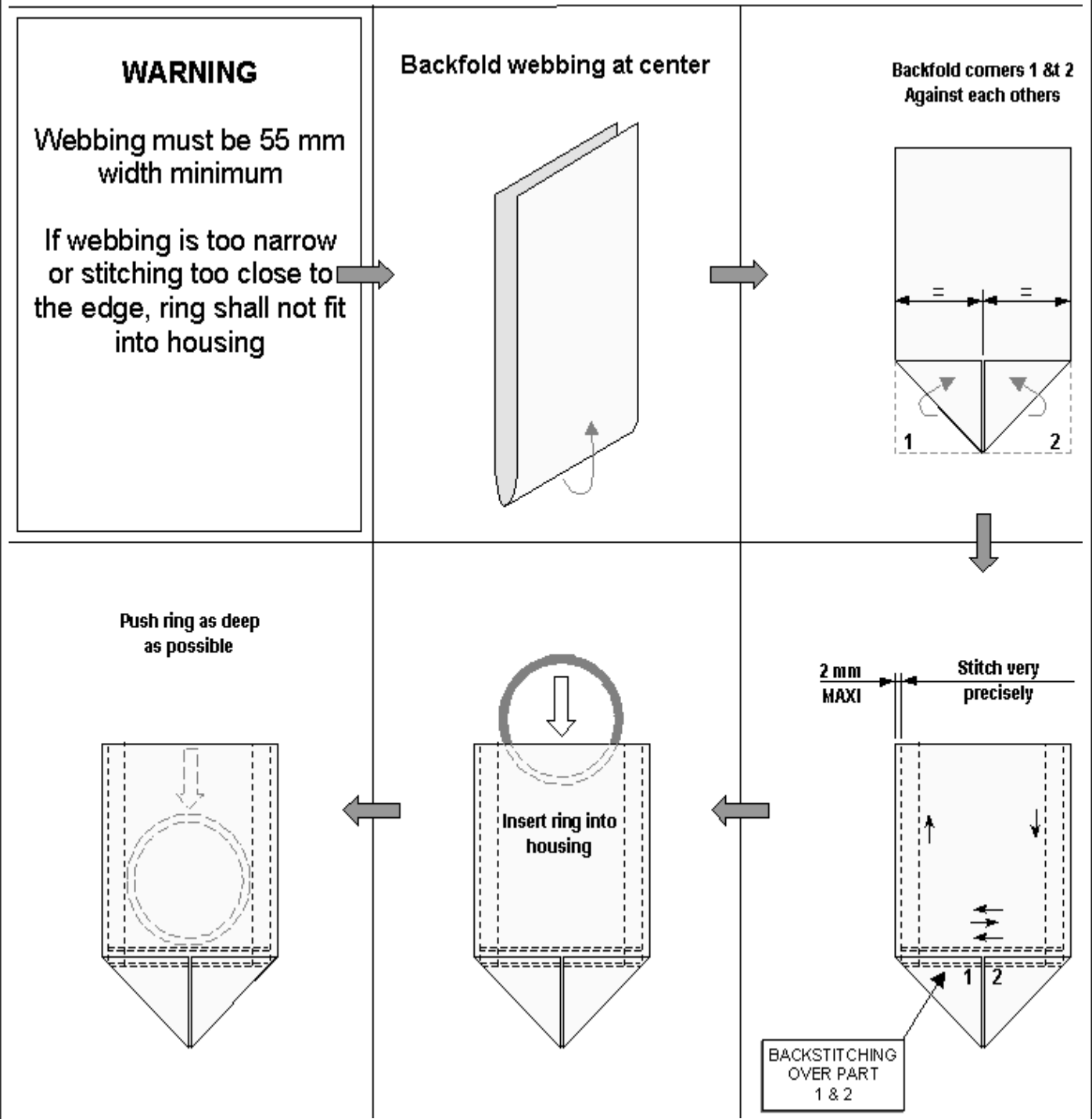

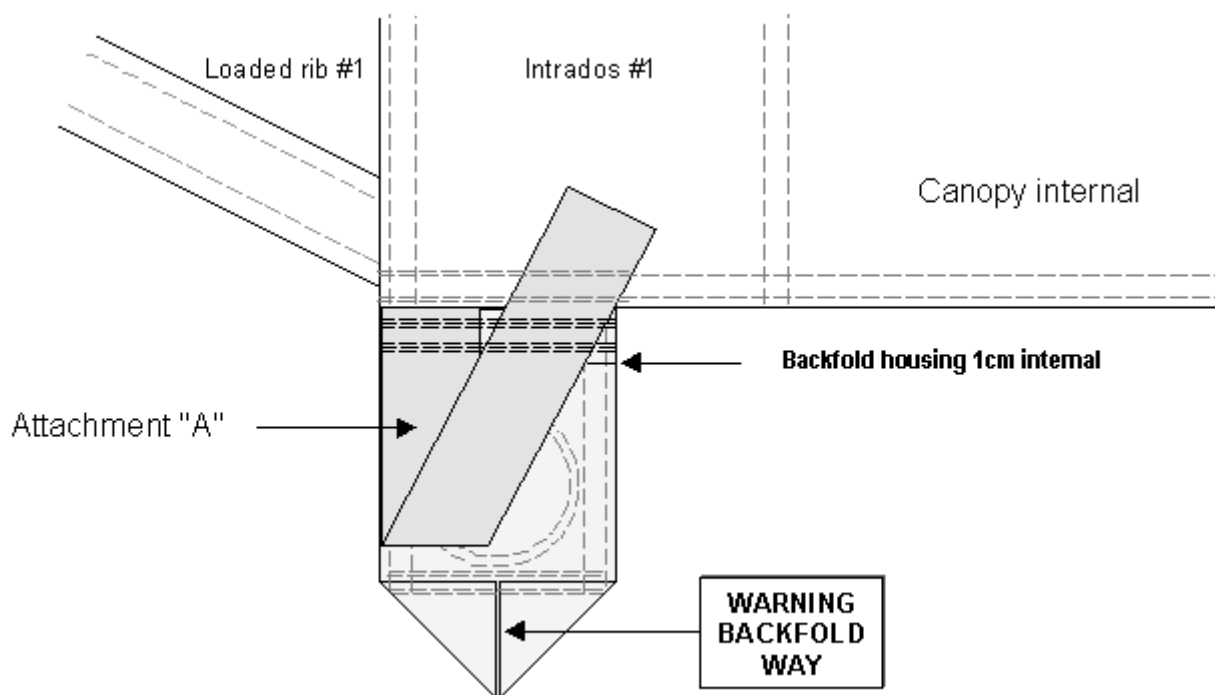
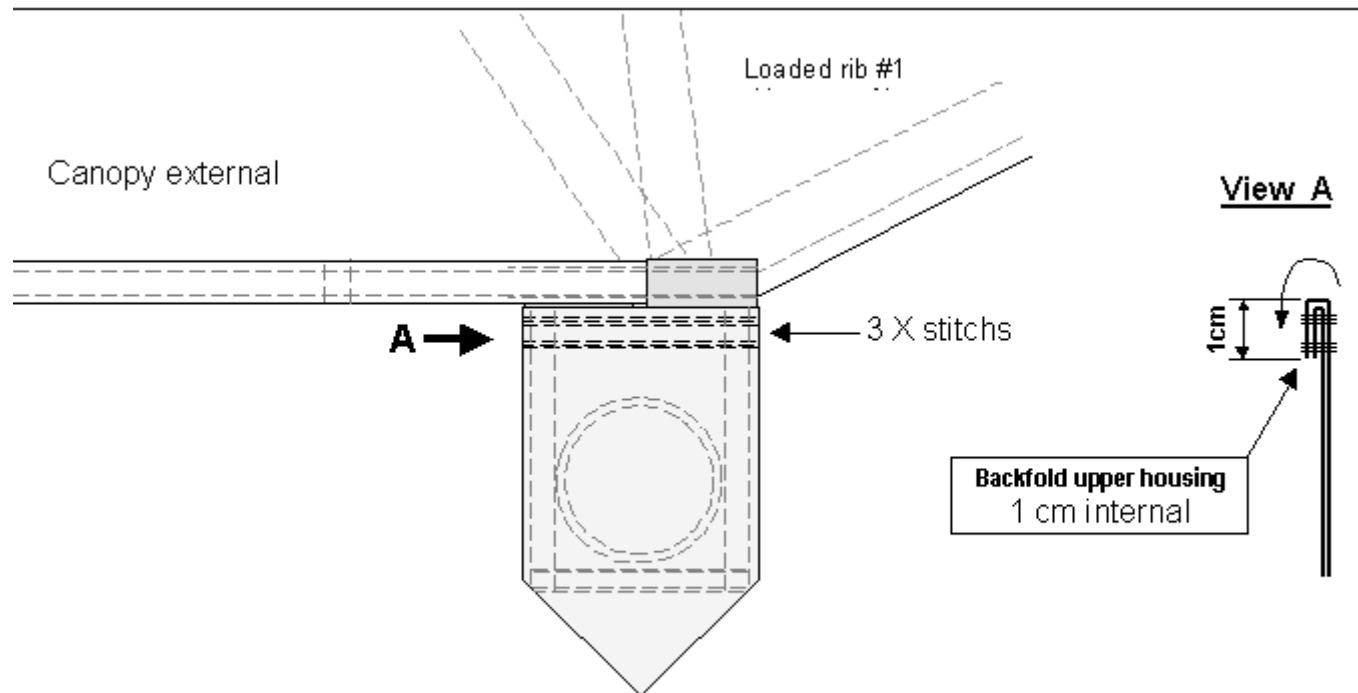

Attention: Tandem masters & qualified riggers

Tél 33 1 34 32 77 77 Fax 33 1 34 32 73 17

BARTACK 25 x 42 USUALLY CARRIED OUT TO LOCK THE A LINE STRAP WILL BE THERE AS WELL USED TO INSTALL THE SLIDER STOP.

WITHOUT AUTOMATIC BARTACK MACHINE, SEWING MUST BE CARRIED OUT USING A 3 STITCH ZIG-ZAG MACHINE.

